

HOFMANN®



TrueCut 401

**OPERATING
INSTRUCTIONS
MANUAL**

11/01 Revised 3/03

TABLE OF CONTENTS

SAFETY INSTRUCTIONS	1
INSTALLATION & SET-UP	4
MOUNTING BRAKE DRUMS	6
OPERATING LATHE (DRUMS)	8
MOUNTING BRAKE ROTORS	11
COMPOSITE ROTORS	12
NON-DIRECTIONAL FINISH	12
OPERATING LATHE (ROTORS)	14
ARBOR REMOVAL & INSTALLATION	17
SERVICE & MAINTENANCE	18
TROUBLE SHOOTING	19
STANDARD TOOLING	23
WIRING DIAGRAM	24

IMPORTANT SAFETY INSTRUCTIONS

Before operating this lathe, basic safety precautions should always be followed, including the following:

READ ALL INSTRUCTIONS

Do not operate equipment with a damaged cord or if equipment has been dropped or damaged, until it has been examined by a qualified service man.

To reduce the risk of electric shock, do not use on wet surfaces or expose to rain.

GROUNDING INSTRUCTIONS

In the event of a malfunction or breakdown, grounding provides a path of least resistance for electric current to reduce the risk of electric shock. This machine is equipped with an electric cord having an equipment-grounding conductor and a grounding plug. The plug must be plugged into a matching outlet that is properly installed and grounded in accordance with all local codes and ordinances. Do not modify the plug provided – if it will not fit the outlet, have the proper outlet installed by a qualified electrician. Improper connection of the equipment-grounding conductor can result in a risk of electric shock. The conductor with insulation having an outer surface that is green with or without yellow stripes is the equipment-grounding conductor. If repair or replacement of the electric cord or plug is necessary, do not connect the equipment-grounding conductor to a live terminal.

Check with a qualified electrician or serviceman if the grounding instructions are not completely understood, or if in doubt as to whether the tool is properly grounded.

EXTENSION CORDS – If necessary use extension cords for 120V-16AWG and a maximum length of 50 feet only. Cords rated for less than the equipment may overheat. Care should be taken to arrange the cord so that it will not be tripped over or pulled. Extension cords are not normally recommended.

Grounded, cord-connected tools intended for use on a supply circuit having a nominal rating less than 150 volts.

This machine is intended for use on a circuit that has an outlet that looks like the one illustrated in Sketch A. The machine has a grounding plug that looks like the plug illustrated in Sketch A. A temporary adaptor, which looks like the adaptor illustrated in Sketches B and C may be used to connect This plug to a 2-pole receptacle as shown In Sketch B if a properly grounded outlet is not available. The temporary adaptor should be used only until a properly grounded outlet can be installed by a qualified electrician. The green colored rigid ear, lug, etc. extending from the adaptor must be connected to a permanent ground such as a properly grounded outlet box.

GROUNDING METHODS

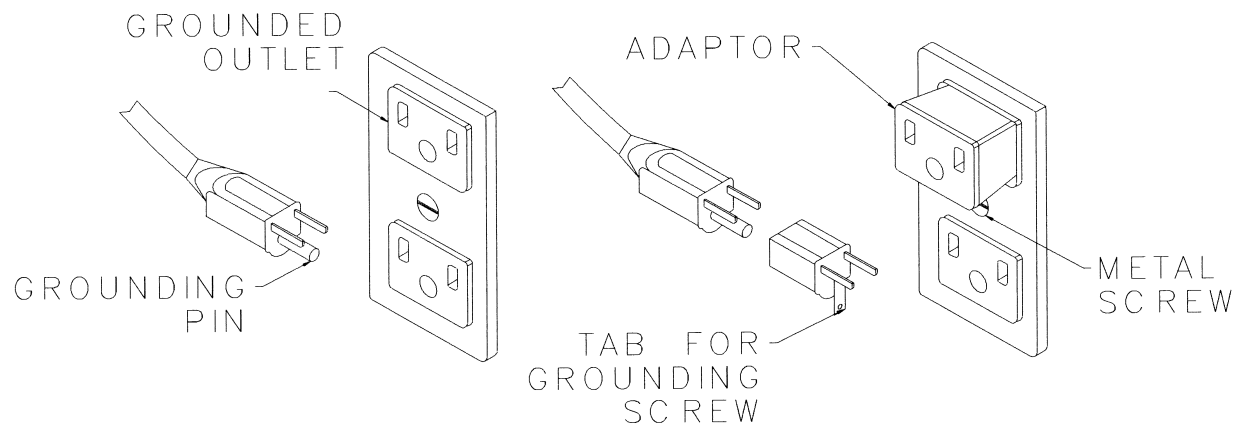

Note: In Canada the use of a temporary adaptor is not permitted by the Canadian Electrical Code.

REDUCE THE RISK OF UNINTENTIONAL STARTING – Make sure switches are in the “OFF” position before plugging cord in.

ALWAYS UNPLUG EQUIPMENT – from electrical outlet when not in use. Never use the cord to pull the plug from the outlet. Grasp plug and pull to disconnect.

SERVICING MACHINE – Disconnect machine before servicing as well as when changing accessories such as tool bits, carbide cutters, etc.

TO REDUCE THE RISK OF FIRE – Do not operate equipment in the vicinity of open containers of flammable liquids (i.e. gasoline).

WEAR PROPER APPAREL – No loose clothing, gloves, neckties, rings, bracelets or other jewelry which may get caught in moving parts. Wear protective hair covering to contain long hair. Non-slip footwear is recommended. Keep all parts of body away from moving parts of machine.

KEEP WORK AREA CLEAN – Cluttered areas and benches invite accidents. Do not let cord hang over edge of table, bench or counter.

REMOVE ADJUSTING KEYS & WRENCHES – Form a habit of checking to see that keys and adjusting wrenches are removed from tool before turning machine on.

DON'T FORCE MACHINE – Don't force machine or attachments to do a job for which they were not designed.

DON'T OVERREACH – Keep proper footing and balance at all times.

ALWAYS USE SAFETY GLASSES – Everyday eyeglasses only have the impact-resistant lens..they are **NOT** safety glasses.

KEEP GUARDS IN PLACE – and in working order. These are installed for your safety.

NEVER LEAVE MACHINE RUNNING UNATTENDED – Turn power OFF. Do not leave machine until it comes to a complete stop. Keep hands away from moving parts.

MAINTAIN MACHINE WITH CARE – Keep machine clean and in good condition for the best and safest performance. Follow instructions for lubricating and changing accessories.

CLEANING MACHINE – DO NOT USE COMPRESSED AIRLINE – use brush or shop vac when machine is not in use.

CHECK DAMAGED PARTS – Any part, guard or adaptor that is damaged should be carefully checked to determine if it will operate properly and perform its intended function. A guard, adaptor or other part that will not fulfil its intended purpose should be replaced or repaired.

NORMAL OPERATION – Machine must be bolted to bench before operation, thus eliminating the possibility of tipping, slipping and vibration on supporting surface.

READ INSTRUCTION MANUAL – on set-up and operation of machine **BEFORE** using. Use only as described in this manual. Use only manufacturers' recommended attachments.

SAVE THESE INSTRUCTIONS.

INSTALLATION AND SET-UP

- 1 Uncrate the lathe and remove from the box.

CAUTION; Do not remove lathe by lifting up on the lathe arbor. There is danger of distorting the arbor and causing runout.

This machine is supplied with a lifting hook. There is a threaded plug located between the carriage and the head, just below the oil level indicator. Remove the plug and install the hook that is supplied. When the lathe is mounted, remove the hook and re-install the threaded plug.

NOTE: Do not run this machine with the hook installed as it will cause damage to the carriage.

- 2 Check the lathe thoroughly and report any damage to the carrier immediately.

- 3 Bolt the lathe onto the bench. This will avoid possible vibrations when operating the lathe. **NOTE:** If the lathe bench is used and placed on an uneven floor, it should be leveled or shimmed and bolted to the floor. If the floor is flat, it is not necessary to bolt bench to floor.

- 4 Place lamp on mounting lug located at the rear of the machine. Plug lamp into lamp receptacle located on the right side of the control panel.

NOTE: The receptacle is for lamp use only. Do not plug other equipment into the outlet.

- 5 Be sure the lathe is plugged into a grounded, 120-volt electrical outlet.

NOTE: The plug must fit into a matching outlet that is properly installed and grounded in accordance with all local codes and ordinances. Do not modify the plug provided. If it will not fit the outlet, have the proper outlet installed by a qualified electrician.

CAUTION: Do not cut off grounding prong. An improper connection can result in a risk of electric shock.

- 6 Check oil level in spindle housing window (1, figure 1) before starting the lathe. Oil level is correct when window indicator shows half full in window. To fill, remove top plate (4, figure 1). Use S A E 90 gear oil.

- 7 Lubricate tool carriage ways and ALL lube points (2 & 3, figure 1) with a good grade SAE 10 oil. **NOTE:** Lathe should be cleaned and oiled daily when in use.

- 8 Clean the lathe arbor, the arbor threads, adaptors, cones and collars of protective coating. Then lubricate adaptors and threads with light oil to protect against corrosion.

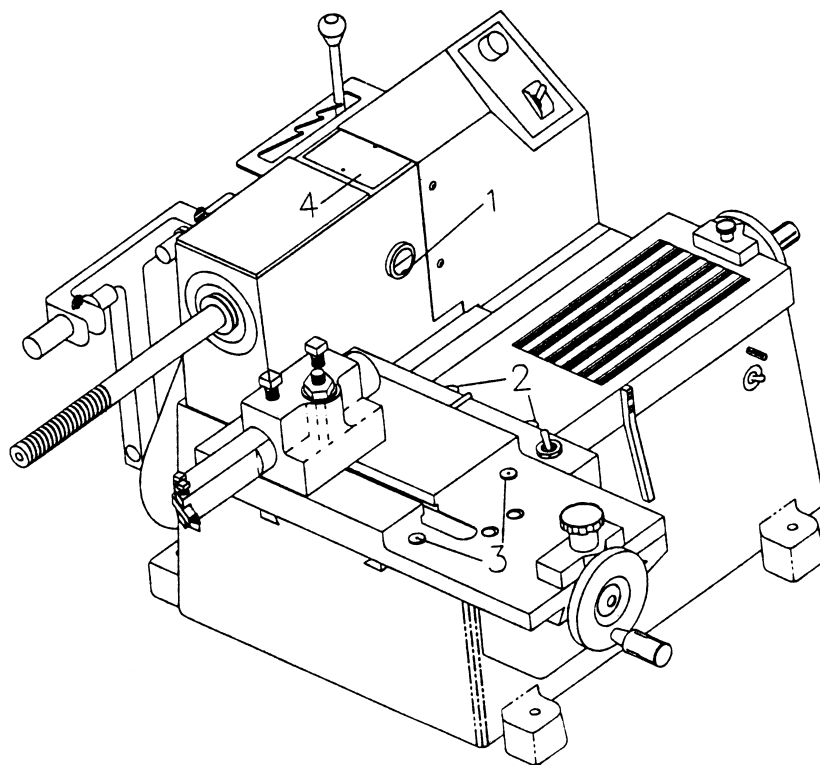

Fig. 1 Lubrication Points

MOUNTING BRAKE DRUMS

1 DRUM WITH HUB

Remove the wheel bearings from the hub and clean the outer bearing races thoroughly. Select the bearing adaptors that fit the bearing races, one for each end of the hub. Mounting is similar to rotors with hub – see A, figure 6.

2 DRUM WITHOUT HUB

Select the taper cone that fits the center hold from inside the drum. Mount the drum on the lathe arbor using a hubless adaptor and spring. See A, figure 2.

CAUTION: Be sure the surfaces of the tapered cone and drum center are thoroughly cleaned. It is often necessary to dress the center hole inner and outer wheel mounting flange with a fine file or sand paper. Dirt or buildup of rust in drum center will cause inaccurate truing of drum surfaces.

NOTE: The tapered cone and spring can be mounted on either side of drum. On small drums they are always mounted on the outside of drum See B, figure 2.

..Mount the brake drum on the arbor using the adaptor(s) and spacers.

NOTE: The brake drum should be mounted as close to the lathe housing as possible. This provides a good stable mounting for best refinishing results.

..Tighten the spindle locking nut tightly. Do not use excessive force.

..Install the drum chatterband tightly around the outside of the drum. Chatterbands must be used to eliminate vibrations.

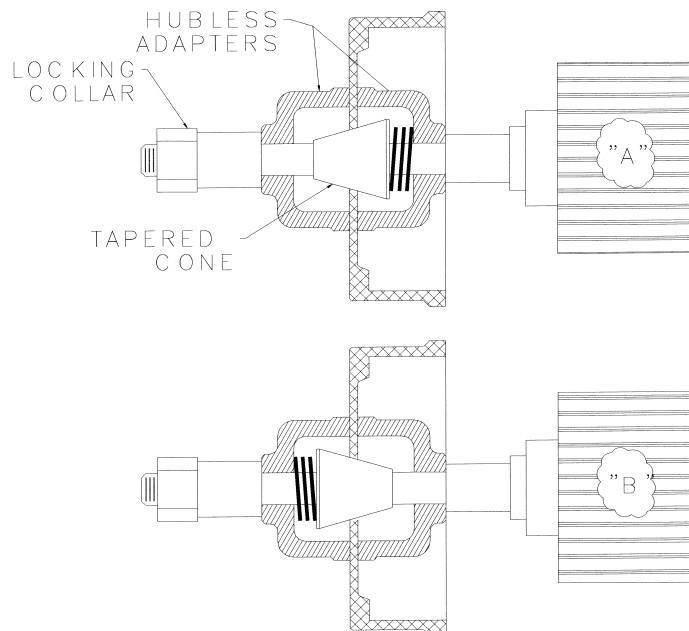

Fig. 2 Typical mounting of drums on lathe arbor

SPINDLE SPEEDS

This machine is equipped with variable spindle speeds. There are four speed selections – 85/110/140/185 RPM. The speed change lever (10, figure 4) is located at the rear of the machine behind the control panel. The lever rides in a speed selector plate (11, figure 4) that is notched for each speed. High speed (185) is all the way to the right and low speed (85) is on the left. To change speeds, position lever in the notch labeled with the desired speed.

NOTE; SPINDLE MOTOR SHOULD BE ON WHEN CHANGING SPEEDS.

APPLICATIONS

85 RPM – For use on large diameter discs or drums found on trucks and buses.

TYPICAL SIZES – 13” dia or larger

110/140 RPM – This is the normal operating range for resurfacing discs and drums on most cars and light trucks up to 1 ton.

TYPICAL SIZES – 8” – 13” dia

185 RPM – For resurfacing smaller discs and drums found on compact cars.

TYPICAL SIZES – 8” dia or less

NOTE: Resurfacing large discs and drums at high spindle speed will result in premature wear of carbide tips.

OPERATING THE LATHE (Brake Drums)

1 Brake Drum Turning Attachment Setup:

BORING BAR LOCK BOLTS

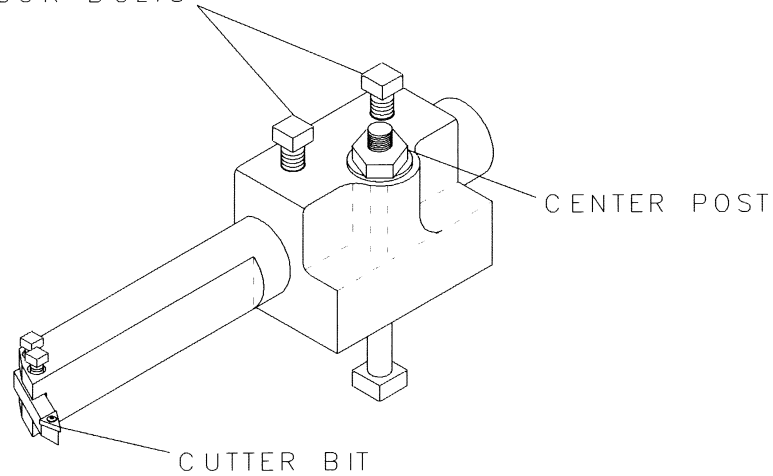

Fig. 3 Drum turning attachment

..install the Brake Drum Turning Attachment on the carriage mounting plate. Insert the center post into the groove of the mounting plate and slide the attachment onto the plate.

..adjust the drum turning attachment so that the boring bar and cutter bit are in line with the drum braking surface.

2 To set the cutting tool (carbide insert) inside the drum:

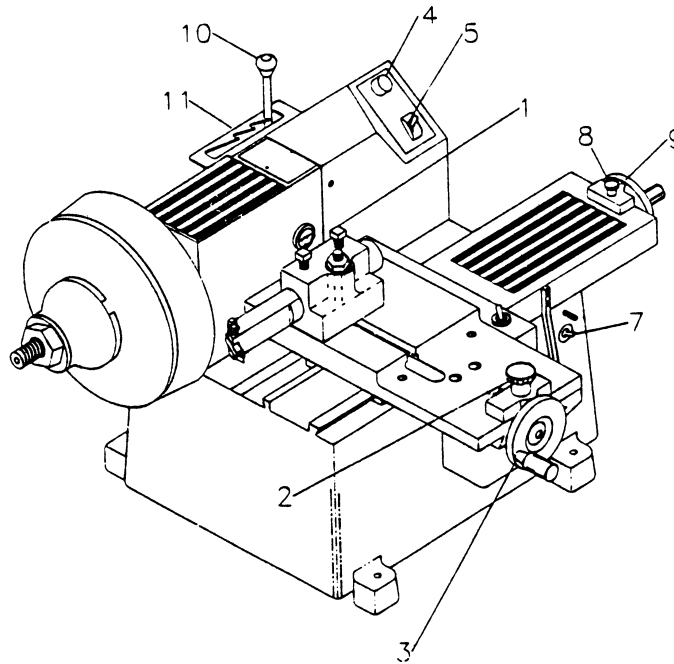

Fig. 4 Lathe controls for refinishing drums

..loosen the boring bar lock bolts (1, figure 4) and both cross-slide and main-slide carriage feed locking knobs (2 and 8, figure 4)

..slide the boring bar inward or outward and turn the cross-slide and main-slide carriage feed handwheels (3 and 9, figure 4) to position the cutting tool bit over the braking surface of the drum.

NOTE: Be sure the cutting tool will travel over the full surface of the drum before the automatic feed switch (7, figure 4) shuts off and stops the travel of the carriage.

..tighten the drum turning attachment center post locking nut (10, figure 4). Then tighten the two boring bar lock bolts.

3 To set desired depth of cut:
..turn both carriage feed switches to “OFF”

..start the brake lathe by moving the spindle selector switch to the drum position (down)

..turn the handwheel (3,figure 4) counter-clockwise until the cutting tool touches the drum surface

..turn the main-slide carriage feed handwheel (9,figure 4) and move the carriage in until the cutting tool bit is just inside the undercut of the drum.

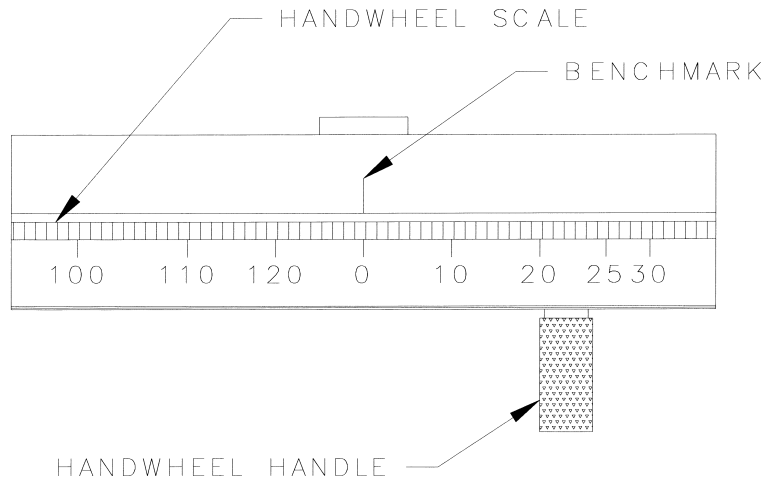

Fig. 5 Handwheel scale

..hold the cross-slide carriage feed handwheel to keep it from turning and adjust the handwheel sleeve until one of the reference numbers on the scale aligns to the benchmark located on the support block. See figure 5

NOTE: Each graduation on the handwheel equals .002" (.05mm)

..now turn the handwheel to the desired depth of cut noting the number of graduation lines past the set reference number. **NOTE:** Recommended depth of cut is .006-.016 or three to eight graduation lines

..turn variable speed feed control (4, figure 4) to a desired setting. **NOTE:** The carriage feed speed ranges from 0” to .008” per revolution. Do not try to cut too much at one time. Smaller cuts (low carriage feed speed) produce a finer finish.

..with depth of cut set, tighten the carriage feed locking knob (2, figure 4). After initial setup, tighten all locks and turn the automatic carriage feed switch “ON” (7, figure 4) **NOTE:** The carriage feed will stop automatically when the cut is complete. The cutting tool boring bar and cutting tool bit feeds from inside of the drum outward.

..if a second cut is necessary, loosen the carriage feed locking knobs (2 and 8, figure 4) and repeat above procedure

..when the drum braking surface is refinished and trued, move the lathe spindle selector switch to “OFF” (center position)

CAUTION: Do not shut off while cutting tool is in contact with the drum. This will cause the carbide cutter (insert) to chip and render it useless.

CAUTION: Arbor, cones, adaptors and spacers must be kept clean and free of nicks to ensure proper alignment of the drum on the arbor. Failure to follow this procedure will result in drums not running true with bearings, thereby causing problems in the braking system of the vehicle.

CLEANING THE LATHE

Be sure lathe is turned “OFF”. Brush or vacuum chips from the lathe and bench.

CAUTION; Never use compressed air for cleaning this lathe.

MOUNTING BRAKE ROTORS

Special Instructions

1 Rotor with hub

Remove the wheel bearings from the hub and clean the bearing cups thoroughly. Select the bearing adaptor that fits the bearing bore one for each end of the hub. See Figure 6A.

CAUTION: Be sure the surfaces of the cones and bearing cups are thoroughly cleaned. Dirt or foreign matter will cause inaccurate truing of the rotor surfaces.

2 Rotor without hub

Select the taper cone that fits the center hole of the rotor. Select the proper hubless adaptors to fit the inside and outside of the rotor. Use the coil spring as shown in figure 6C.

CAUTION; Be sure the surfaces of the tapered cone and rotor center are thoroughly cleaned. It is often necessary to dress the center hole, inner and outer wheel mounting flange with a fine file or sandpaper. Dirt or buildup of rust on rotor centers will cause inaccurate truing of the rotor surfaces.

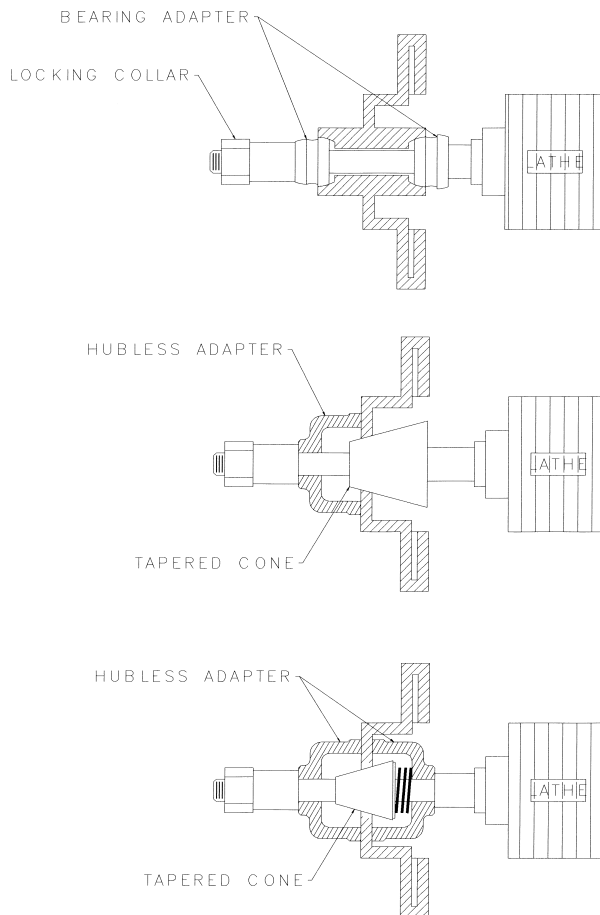

Fig. 6 Typical mountings of rotors

COMPOSITE ROTORS

Some late model automobiles use “composite “ rotors. To resurface these rotors within manufacturers specifications, special tooling has been developed. This tooling clamps the rotor so that close machine tolerances can be kept and a proper surface is produced. Failure to use this special tooling will result in an out of tolerance rotor surface. The rotor may exceed specifications concerning parallelism and runout. This can cause brake pedal pulsations, noise and reduce life of the brake components.

NON-DIRECTIONAL ROTOR REFINISHER

To follow the recommendation of some automobile manufacturers specifications, a non-directional or “swirl” finish may be required. This finish is to be applied to a resurfaced rotor. Always check the manufacturers specifications.

Composite rotor tooling and non-directional finishing tools are available upon request.

1. Select the proper tooling and mount the rotor on the spindle shaft.
NOTE: Rotor should be positioned as close to the lathe housing as possible. This provides a good stable mounting for best refinishing results.
2. Position the rotor stabilizer over the rotor and adjust the spring-loaded bronze plungers of the stabilizer to provide light tension against the surfaces of the rotor.
NOTE: The stabilizer is used in place of the standard chatterband for rotors. The stabilizer is designed to eliminate chatter on rotors of varying thickness and diameters. Spring loaded bronze fingers press against the rotor surfaces during the refinishing operation.

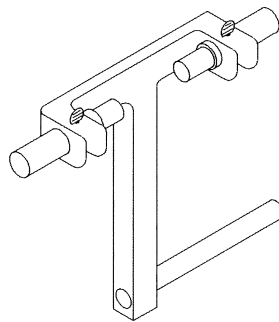

Fig. 7 Rotor Stabilizer

2 Rotor Turning Attachment Setup

- a. Install the disc Brake Rotor Turning Attachment on the carriage mounting plate. Insert the center post into the groove of the mounting plate and slide the holder onto the plate
- b. Rotate both cross-slide and main drive carriage feed handwheel(s) (1 and 2, figure 9) inward or outward to position the cutting tool bits so that the rotor is centered between them.

NOTE: Be sure the cutting tool bits will travel over the full surfaces of the rotor before the automatic feed switch (3, figure 9) shuts off and stops the travel of the carriage.

- c. Tighten rotor turning attachment center post locking nut firmly (4, figure 9)

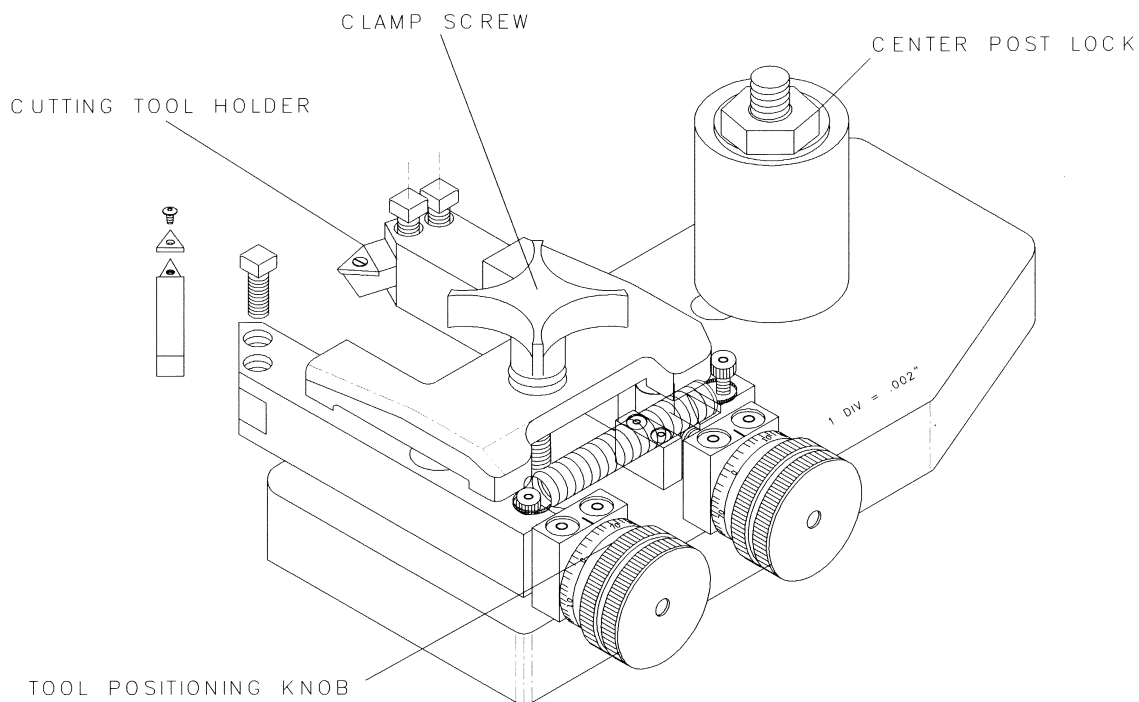

Fig. 8 Rotor turning attachments

OPERATING THE LATHE (Brake Rotors)

- 1 To set the cutting tools (carbide inserts) to the undercut of the rotor surfaces:
 - a. Start the lathe by moving the spindle selector switch to the “Disc” position (up)
 - b. Turn the cross-slide carriage feed handwheel (1, figure 9) and move carriage in until the cutting tool bits are positioned over the braking surfaces of the rotor.

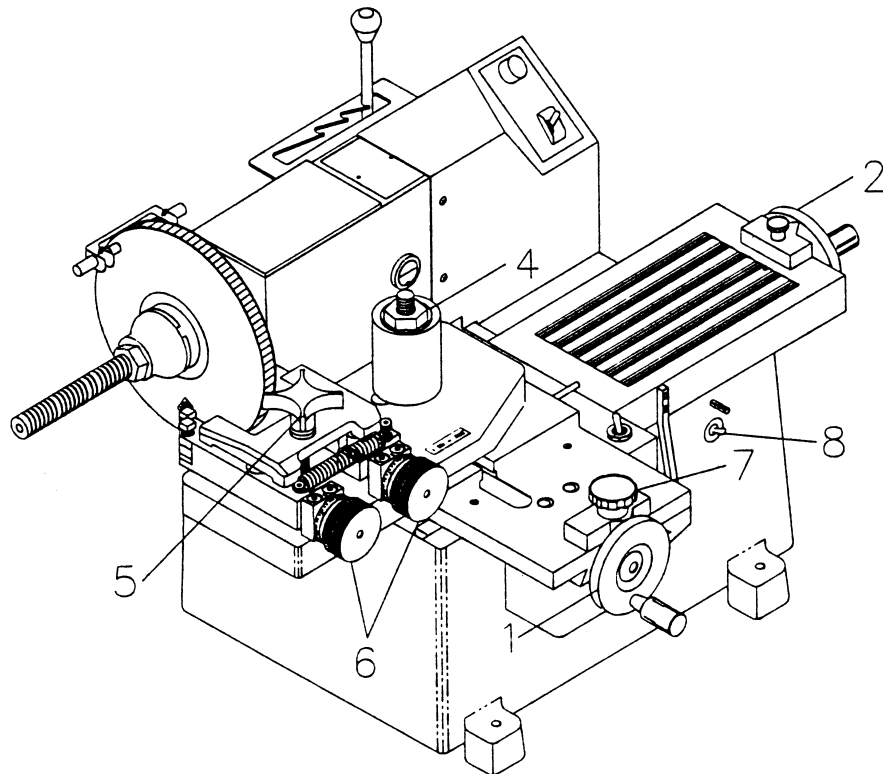
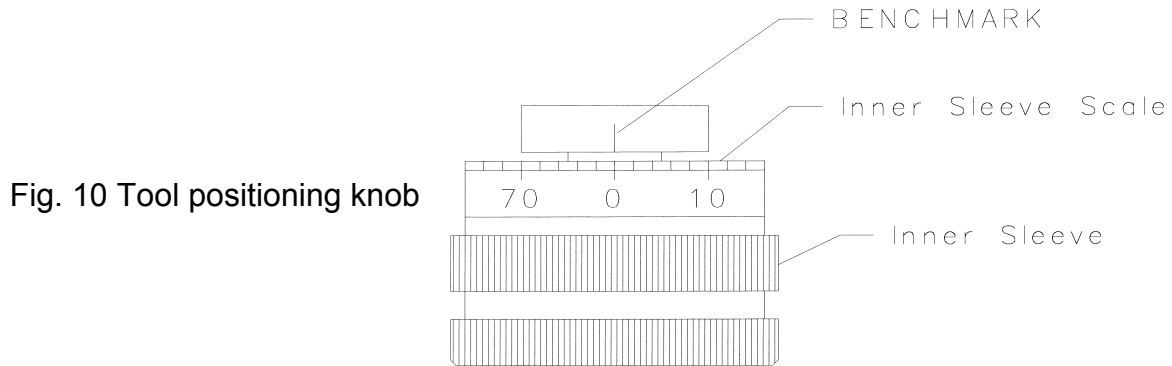

Fig. 9 Lathe controls for refinishing discs

- c. Turn tool positioning knob (6, figure 9) on one side, until the cutting tool bit touches the surface of the rotor. Set the cutting tool bit on the other side of the rotor the same way.
- d. Then move the carriage in until the cutting tools are just inside the undercut of the rotor.

2 To set the desired depth of cut:



A Turn both carriage feed switches to “OFF”

B Hold the tool positioning knob to keep it from turning and adjust the inner sleeve until zero or one of the reference numbers on the scale aligns to the benchmark located on the support block. See Figure 10. Repeat on the other positioning knob.

NOTE: Each graduation line on the inner sleeve of the tool positioning knob is .002” (.05 mm)

C Now turn the tool positioning knob to the desired depth of cut, noting the number of graduation lines past the set reference number.

NOTE: Recommended depth of cut is .006”-0.010” on each rotor surface or three to five graduation lines.

D Turn the variable speed control to a desired setting.

NOTE: The carriage feed speed ranges from 0” to .008” per revolution. Do not try to cut too much at one time. Smaller cuts (low carriage feed speed) produce a finer finish.

E With depth of cut set, tighten the tool holder clamp screw (5, figure 9)

F Tighten the carriage feed locking knob (7, figure 9). After initial setup, tighten all locks and turn the automatic carriage feed switch “ON” (3, figure 9)

NOTE: The carriage feed will stop automatically when the cut is complete.

G If a second cut is necessary, loosen the carriage feed locking knob and cutting tool holder clamp screw. Turn the carriage feed handwheel and move the carriage in until the cutting tool bits are just inside the undercut of the rotor. Then repeat above procedure, Steps A-E.

H When the rotor braking surfaces are refinished and trued, move the spindle selector switch to “OFF (center position)

CAUTION: Do not shut lathe off while cutting tool is in contact with the rotor. This will cause the carbide cutters to chip and render them useless.

CAUTION: Spindle shaft cones, adaptors and spacers must be kept clean and free of nicks to ensure proper alignment of the rotor on the spindle. Failure to follow this procedure will result in rotors not running true with bearings, thereby causing problems in the braking system of the vehicle.

NOTE: All standard drum and rotor adaptors and spacers are interchangeable.

CLEANING THE LATHE

Be sure the lathe is turned "OFF". Brush or vacuum chips from the lathe and bench.

CAUTION; Never use compressed air for cleaning this lathe.

ARBOR REMOVAL AND INSTALLATION

The Combination Brake Lathe is equipped with a standard 1" diameter arbor. The lathe allows the removal of the standard and the installation of one of the optional arbors.

TO REMOVE:

- 1 Loosen the draw bolt three or four turns using an Allen wrench. See fig.11.
- 2 Place the W110 cone on the spindle shaft and screw the spindle nut on. With one hand, slide the cone from right to left hard enough to loosen the shaft taper. **NOTE:** Care must be taken not to crush a finger between the spindle nut and the cone when loosening the taper.
- 3 Hold the arbor and unthread the draw bolt. The arbor will slip free of the tapers of the spindle.

TO INSTALL;

- 1 Clean both tapers (arbor and spindle) to remove any foreign material. Dirt on these surfaces will cause shaft runout.
- 2 Slide the arbor into the spindle. Align the "O" marks on both until they are in line with each other as shown in Figure 10 and tighten the draw bolt.

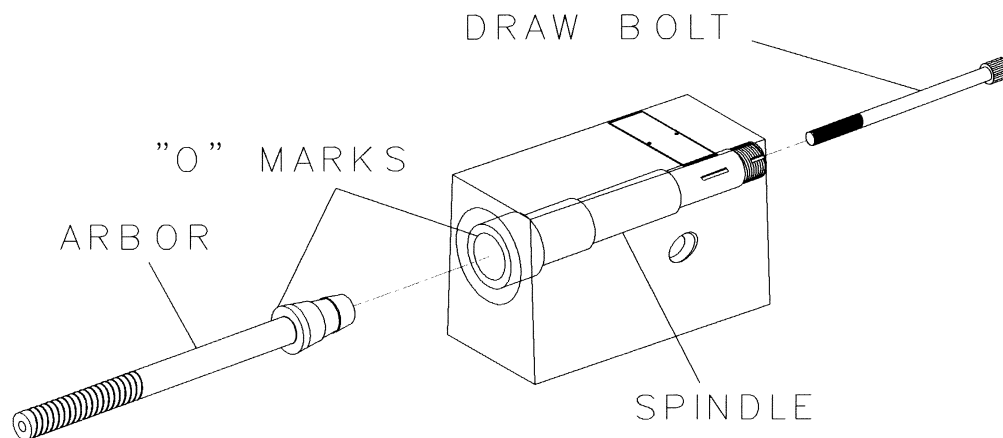

Fig. 11 Changing lathe arbor

SERVICE AND MAINTENANCE

LUBRICATION

A Check oil level periodically by checking the window in the lathe housing. Oil level is correct when indicator window shows half full. Use S A E 90 gear oil.

B Lubricate tool carriage ways and ALL lube points with a pressure type oil can using 10W30 oil.

NOTE: Lathe should be cleaned and oiled daily when in use. This will assure minimum wear of lathe gibs and ways.

CLEANLINESS

Clean the lathe daily when in use. Use a suitable brush or cloth. A vacuum cleaner may also be used.

CAUTION; Never use compressed air.

CUTTER BITS (Carbide Inserts)

The tri-corner tool bits allow for three cutting edges.

To replace or to rotate to a new cutting edge, remove the cutter bit mounting screw. Be sure mounting screw is tightened firmly after changing the cutter bit.

NOTE: It is recommended to maintain a chart or record whenever cutter bits are replaced or rotated.

NOTE: Cutter bits are changed whenever a rough or wavy finish appears on the braking surfaces of the drum or rotor. This indicates a worn or chipped cutting edge.

TROUBLE SHOOTING

PROBLEM; Main motor will not run

CAUSE: The overload switch on the motor cuts in due to overloading the motor with a large cut or using a very long extension cord between the power source and the machine

REMEDY: Let motor cool down, then push reset button on back of the motor

NOTE: The reset button may be reached through hole provided in the top of the bench

.....
PROBLEM: Rough finish on disc and drum

CAUSE #1: Worn or broken tool bit

REMEDY: Index carbide to new corner or replace

CAUSE #2: Excessive play in the drum carriage

REMEDY; The cross slide is adjustable for play by means of a row of bolts along the lower front edge of the carriage. These bolts have locknuts to keep them in place. Loosen the locknuts and adjust screws until there is a slight drag when moving the carriage back and forth. Tighten the locknuts while holding the adjusting screws in place.

NOTE: Carriage must be over dovetail plate while adjusting carriage for excessive play

CAUSE #3: Drum boring bar or tool holder is not a proper angle

REMEDY: Loosen locking bolts on center post of the drum turning attachment and position it to obtain a more optimum angle (inward toward drum surface)

CAUSE #4: Excessive play in main slide carriage

REMEDY: The main slide carriage is adjustable for play by means of a row of bolts along the lower left edge of the carriage. These bolts have locknuts to keep them in place. Loosen the locknuts and adjust the screws until there is a slight drag when moving the carriage back and forth. Tighten the locknuts while holding the adjusting screws in place.

NOTE: Carriage must be over dovetail plate while adjusting the carriage for excessive play.

CAUSE #5: Cut is too large.

REMEDY: Do not try to cut too much at one time. Smaller cuts produce a finer finish

CAUSE #6: Speed control set on rough cut

REMEDY: Slow feed down

.....
PROBLEM; The end of the arbor wobbles when a drum or rotor is mounted

CAUSE: Sometimes when a rotor flywheel or drum is mounted the end of the shaft will wobble. When the arbor nut is loosened the shaft will run true. This is NORMAL. Rotor and drum surfaces are rarely flat. When tightening the arbor nut, the arbor will twist toward the lowest part of the mounting surface.

REMEDY: What can you do to reduce arbor wobble?

- 1 Prepare the surfaces the tooling will touch to insure they are flat and smooth. If machining a hubless part, use a file to dress the center hole at the point where the mounting cone will touch. If a hub type, wipe out the old grease and inspect the bearing races for wear or unevenness. Replace if necessary. Remove sharp edges and burrs.
- 2 Use the self-aligning washers (W223 & W224) found in the tooling supplied with the lathe. Place the self-aligning washers on the arbor just after the last cup, bearing adaptor or cone.
- 3 Insure that the tooling is clean and free of nicks.
- 4 If machining a rotor, use a dial indicator with the rotor mounted on the vehicle to find the high spot on the friction surface. Mark the high spot. Remove the rotor, mount it on the brake lathe and use a dial indicator to check for the location of the high spot. If they differ, readjust the tooling and adjust until the high spot agrees with the mark found when mounted on the vehicle.
- 5 As an alternate method to 4 or when machining a drum, do a scratch test:
 - a Mount the drum, rotor or flywheel and switch the lathe on
 - b Adjust the cutting bit until it just touches the friction surface
 - c Back the cutter from the surface and turn the lathe off. The scratch in the surface will indicate the high spot.
 - d Loosen the tooling and rotate the part 180 deg.(without rotating the tooling). Tighten.
 - e Move the line cutter to another spot on the friction surface and make another scratch test. If the scratches line up, the part is properly mounted and can be machined. If the scratches do not line up, loosen and adjust the tooling until they do.

PROBLEM: The arbor wobbles without a drum or rotor mounted.

CAUSE #1: The arbor has not been properly installed.

REMEDY: To insure true running, insure that the “O” witness marks found on the arbor and lathe shafts are aligned and the arbor is tight. See the **ARBOR REMOVAL AND INSTALLATION** section of this manual.

CAUSE #2: The arbor is bent. Using a dial indicator, measure the runout of the arbor about six inches from the headstock. The allowed tolerance is 0.001” (0.025mm)

REMEDY: Replace the motor



PROBLEM; Fish scale pattern in the machined surface.

IF ROTOR ONLY:

CAUSE #1: The rotor stabilizer has not been used or used incorrectly

REMEDY: The rotor stabilizer should be attached so that the plungers are pushing against the friction surface with even pressure. When machining thin, solid, non-vented rotors, the silencer bands can be used with the stabilizer to give extra vibration dampening.

IF DRUMS & FLYWHEELS ONLY:

CAUSE #1: The angle of the boring bar is incorrectly positioned.

REMEDY: Adjust the bar in the holder so that a minimum of the bar at the cutting bit end is exposed. Adjust the angle of the boring bar holder so the cutting bit is pointing as close as possible to a right angle to the friction surface. The tip of the bit should be used for machining, not the side.

CAUSE #2: If a drum, the silencer band was not used or is attached incorrectly.

REMEDY: Attach the band tightly so that it covers as much of the drum as possible. If turning especially wide drums, it may be necessary to use a second silencer band, BDL 140, or optional wide band, BDL 140-1.

IF DRUMS, FLYWHEELS OR ROTORS;

CAUSE #1: The part has been mounted too far out on the arbor.

REMEDY; Always mount the part to be machined as close to the headstock as possible.

CAUSE #2: The bench is not tightly bolted together. The lathe is not bolted to the bench or the bench can rock on the uneven floor.

REMEDY: Tighten the bench hardware. Make sure the lathe is bolted securely to the bench. Adjust the legs to insure the bench will not rock.

CAUSE #3: The carriage feed speed is set too low.

REMEDY: Increase the feed speed. Acceptable machining is usually maintained with the adjustment knob set to the 3 o'clock scale position.

CAUSE #4: The cutter bit(s) is loose or chips are lodged between the bit and the holder or the holder(s) is loose.

REMEDY: Remove the carbide bit(s). Clean any chips from the holder. Tighten the bit attachment screw and the holder mounting screws.

CAUSE #5: The arbor drive motor v-belt is defective or the motor is loose, causing a vibration throughout the lathe and bench.

REMEDY: Replace the v-belt. Tighten the motor.

CAUSE #6: The depth of cut is set too small.

REMEDY: Adjust depth of cut to remove at least 0.002".

CAUSE #7: The wrong carbide cutter bits and/or holder are used.

REMEDY: Use the proper bits and holder. The correct bits are positive with a 0.015" radius, p/n W139. The holder part number is W140 for rotors or W140-1 for drums.

Standard Tooling 401

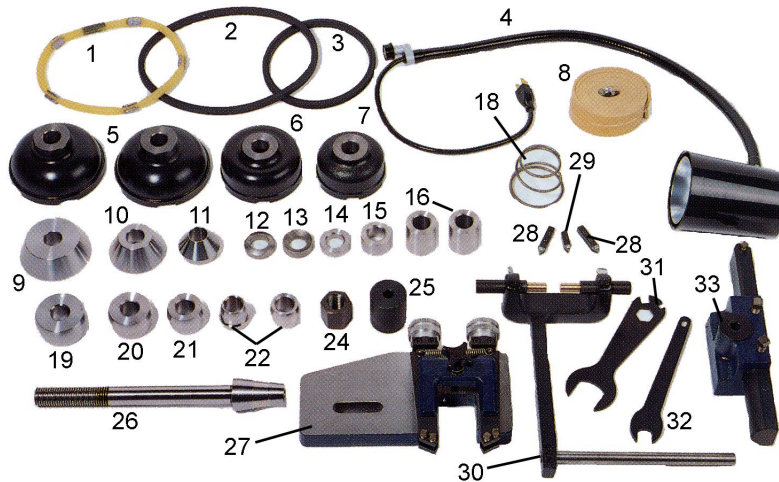

1	W117	Chatterband
2	W116	Chatterband
3	W131	Chatterband
4	BDL251-1	Lamp
5	CW96	Hubless Adapter 1" bore, 5.5" diameter (2)
6	W115	Hubless Adapter 1" bore, 4.75" diameter
7	W114	Hubless Adapter 1" bore, 4" diameter
8	BDL140	Chatterband
9	W110	Cone 1" bore, 3" to 4"
10	W111	Cone 1" bore, 2" to 3.125"
11	CW94	Cone 1" bore, 1.150" to 2.350"
12	W223	Self-Aligning washer Convex
13	W224	Self-Aligning washer Concave
14	W98	Spacer 1" bore, 1/2" long
15	W99	Spacer 1" bore, 1" long
16	W101	Spacer 1" bore, 2" long (2)
18	W108	Spring
19	W129	Bearing adapter 1" bore 2.407" to 2.781"
20	W119	Bearing adapter 1" bore 2.033" to 2.407"
21	W133	Bearing adapter 1" bore, 1.659" to 2.033"
22	W118	Bearing adapter 1" bore, 1.285" to 1.659" (2)
24	W220	Nut
25	CL622	Spacer
26	CL538	Arbor 1" bore, 10.5" long
27	CL605A	Disc Tool Plate
28	W140	Tool bit holder with bit
29	W140-1	Tool bit holder with bit
30	CL503A	Rotor Stabilizer
31	W221	Wrench
32	W230	Wrench
33	CL502A	Drum Tool Plate

Wiring Diagram

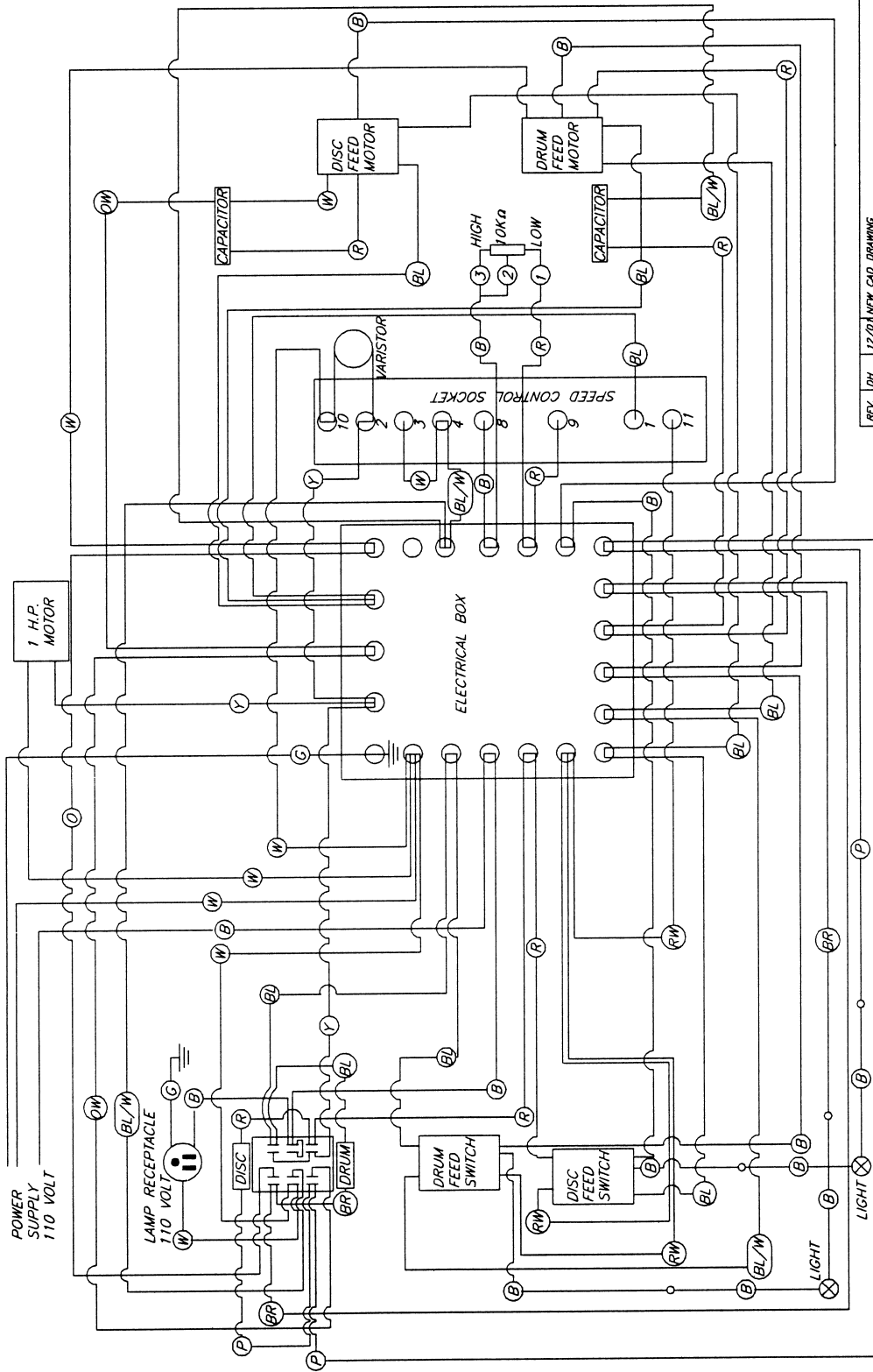

REV.	12/01	NEW CAD DRAWING	DATE	DESCRIPTION					
					DESCRIPTION: 401 TRUECUT MATERIAL: XXX ± .005 DRAWN BY: D. HARDILL SCALE: 100 NOT SCALE DATE: 12/01				

BR	BROWN	BL	BLUE	Y	YELLOW
B	BLACK	R	RED	P	PURPLE
G	GREEN	W	WHITE	BL/W	BLUE/WHITE
RW	RED/WHITE	O	ORANGE	OW	ORANGE/WHITE